

Instruction and Operation Manual

S217

Dew Point Transmitter



Dear Customer,

Thank you for choosing our product.

The operating instructions must be read in full and carefully observed before you start up the device. The manufacturer cannot be held liable for any damage which occurs as a result of non-observance or non-compliance with this manual.

Should the device be tampered with in any manner other than a procedure which is described and specified in the manual, the warranty is void and the manufacturer is exempt from liability.

The device is destined exclusively for the described application.

SUTO offers no guarantee for the suitability for any other purpose. SUTO is also not liable for consequential damage resulting from the delivery, capability or use of this device.

Table of contents

1 Safety Instructions.....	4
2 Registered Trademarks.....	6
3 Application.....	6
4 Features.....	6
5 Technical Data.....	7
6 Dimensional Drawing.....	8
7 Electrical Connection	9
8 Modbus Output (S217-8 and S217-9).....	10
8.1 Modbus Information.....	10
8.2 Modbus Holding Register Table.....	11
8.3 Interpretation of System Status.....	12
9 Installation	13
9.1 Installation Requirements.....	13
9.2 Installation Procedure	14
9.2.1 Install with Measuring Chamber A699 3491.....	14
9.2.2 Install with By-pass Measuring Chamber A699 3493.....	15
9.2.3 Install without Measuring Chamber.....	17
9.3 Remove the Dew Point Transmitter.....	18
9.4 Order Information.....	18
10 Calibration.....	19
11 Maintenance.....	19
12 Disposal or Waste.....	19

1 Safety Instructions

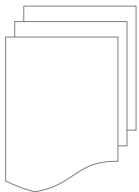

Please check if this instruction manual matches with the product type.

Please observe all notes and instructions indicated in this manual. It contains essential information which must be observed before and during installation, operation and maintenance. Therefore this instruction manual must be read carefully by the technician as well as by the responsible user / qualified personnel.

This instruction manual must be available at the operation site of the Dew Point Transmitter at any time. In case of any obscurities or questions, regarding this manual or the product, please contact the manufacturer.



WARNING!

Compressed air!

Any contact with quickly escaping air or bursting parts of the compressed air system can lead to serious injuries or even death!

- Do not exceed the maximum permitted pressure range (see sensors label).
- Only use pressure tight installation material.
- Avoid that persons get hit escaping air or bursting parts of the instrument.
- The system must be pressureless during maintenance work.



WARNING!

Voltage used for supply!

Any contact with energized parts of the product, may lead to a electrical shock which can lead to serious injuries or even death!

- Consider all regulations for electrical installations.
- The system must be disconnected from any power supply during maintenance work.
- Any electrical work on the system is only allowed by authorized qualified personal.

**ATTENTION!****Permitted operating parameters!**

Observe the permitted operating parameters, any operation exceeding this parameters can lead to malfunctions and may lead to damage on the instrument or the system.

- Do not exceed the permitted operating parameters.
- Make sure the product is operated in its permitted limitations.
- Do not exceed or undercut the permitted storage and operation temperature and pressure.

General safety instructions

- It is not allowed to use the product in explosive areas.
- Please observe the national regulations before/during installation and operation.

Remarks

- It is not allowed to disassemble the product.
- Always use spanner to mount the product properly.

**ATTENTION!****Measurement values can be affected by malfunction!**

The product must be installed properly and frequently maintained, otherwise it may lead to wrong measurement values, which can lead to wrong results.

Storage and transportation

- Make sure that the transportation temperature of the transmitter is between $-30 \dots +70^{\circ}\text{C}$.
- For transportation it is recommended to use the packaging which comes with the transmitter.
- Please make sure that the storage temperature of the transmitter is between $-10 \dots +50^{\circ}\text{C}$.
- Avoid direct UV and solar radiation during storage.
- For the storage the humidity must be $<95\% \text{ rH}$, no condensation.

2 Registered Trademarks

SUTO® Registered trademark of SUTO iTEC

MODBUS® Registered trademark of the Modbus Organization, Hopkinton, USA

3 Application

The SUTO Dew Point Transmitter S217-OEM provides reliable and long term stable dew point monitoring in industrial applications. The newly developed transmitter features improved signal and stability in demanding industrial applications.

It's designed for OEM applications in desiccant and refrigeration dryers.

The measured dew point is output via the loop-powered 4 ... 20 mA signal. Parameters such as analogue output scaling, physical units, can be set ex factory.

4 Features

- Small size makes it ideal for dryer installations
- Measures dew points down to -60°C Td
- 2-wire loop powered sensor or 3-wire
- Modbus/RTU signal output (model depending)
- IP65 casing provides robust protection in rough industrial environment
- Very fast response time ensures safe and reliable indication whenever dew points are out of valid ranges
- Can be installed directly into dryers through G 1/2" thread
- High accuracy of 1 ... 2°C Td dew point
- Withstands condensation

5 Technical Data

CE	
Measuring range (model depending)	-60 ... +20°C Td -50 ... +20°C Td -20 ... +50°C Td
Accuracy *	±1°C Td [-5 ... +50°C] ±2°C Td [-60 ... -5°C]
Pressure range	-0.1 ... 5.0 MPa -0.1 ... 35 MPa (optional)
Power supply	12 ... 30 VDC
Measured gas	Non-corrosive gases
Ambient temperature	-20 ... +50°C
Ambient humidity	0 ... 100% rH
Transport temperature	-30 ... +70°C
Response time t_{90} (@ 4 l/min)	-40°C Td → -20°C Td: 20 seconds 0°C Td → -40°C Td: 120 seconds
Output signal	4 ... 20 mA, 2-wire (S217-0 / S217-3) 4 ... 20 mA, 3-wire (S217-4 / S217-5) Modbus/RTU (S217-8 / S217-9)
Cable	M8 connector, 1.8 m, open wires, 4 poles
Casing	Process connection: stain-less steel Casing: Al alloy
Cassification	IP65
Process connection	G ½" thread (ISO 228/1)
Sensor protection	Stainless steel sinter filter pore size <30 µm
Approval	CE

*** Stated accuracy under following conditions:**

- Ambient / process temperature 23 ± 3°C
- Ambient humidity <95% rH, no condensation
- Airflow > 2 l/min at sensor tip

6 Dimensional Drawing

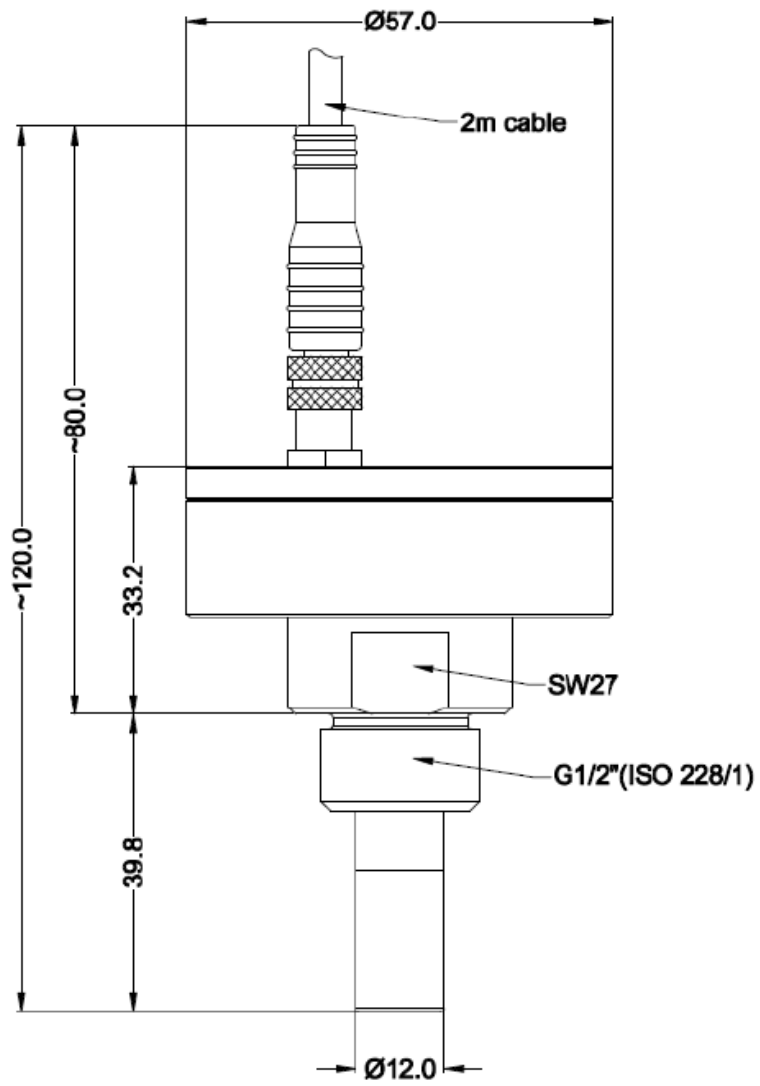

7 Electrical Connection

Pin assignment

	Pin 1	Pin 2	Pin 3	Pin 4	
2-wire	SDI	-VB	+VB	N/A	
3-wire	SDI	-VB	+VB	+I	
Modbus/RTU	-D	-VB	+VB	+D	
Color	Brown	White	Blue	Black	

Legend for pin assignment

SDI	Digital signal (Internal use only)
-VB	Negative supply voltage
+VB	Positive supply voltage
+I	4 ... 20 mA (3-wire)
+D	Positive data Modbus
-D	Negative data Modbus

Schemas

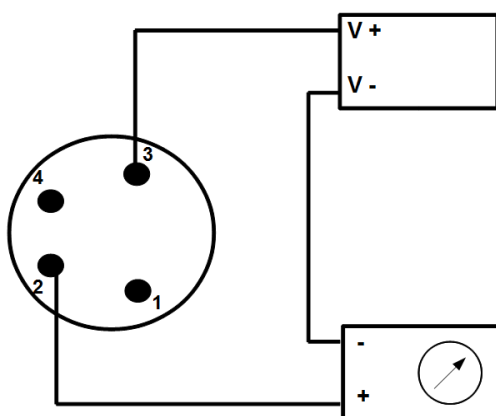

2 Wires (loop powered)

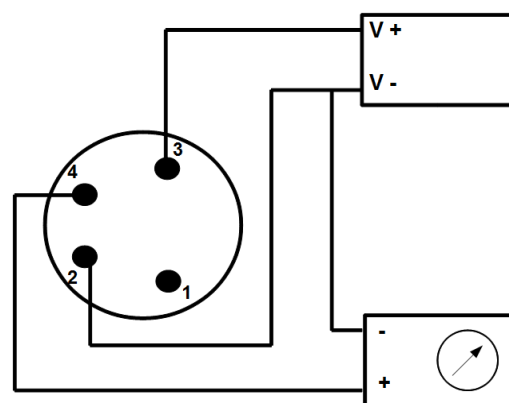

3 Wires

8 Modbus Output (S217-8 and S217-9)

8.1 Modbus Information

The default settings of the Modbus interface are as follows:

Mode	: RTU
Baud rate	: 19200
Device address	: last two digits of serial number
Framing / parity / stop bit	: 8, N, 1
Response time	: 1 second
Response delay	: 0 ms
Inter-frame spacing	: 7 char

Response message that the device returns to the master:

- Function code: 03

The information of the byte order is shown in the table below:

Byte Order	Sequence				Data Type
	1st	2nd	3rd	4th	
1-0-3-2	Byte 1 (MMMMMMMM*)	Byte 0 (MMMMMMMM *)	Byte 3 (SEEEEEEE)	Byte 2 (EMMMMMMM *)	FLOAT
1-0-3-2	Byte 1	Byte 0 LSB	Byte 3 MSB	Byte 2	UINT32 INT32
1-0	Byte 1 MSB	Byte 0 LSB	---	---	UINT16 INT16
1-0	Byte 1 XXX*	Byte 0 DATA	---	---	UINT8 INT8

* S: Sign, E: Exponent, M: Mantissa, XXX: no value

Explanations of MSB and LSB

MSB MSB refers to Most Significant Byte first, which follows the Big-Endian byte order.

For example, if the main system follows the MSB first order:

When the 4-byte floating number, in the order of Byte1-Byte0-Byte3-Byte2, is received from the slave (sensor), the master must change the byte order to Byte3-Byte2-Byte1-Byte0 for the correct display of the value.

LSB LSB refers to Least Significant Byte first, which follows the Little-Endian byte order.

For example, if the main system follows the LSB first order:

When the 4-byte floating number, in the order of Byte1-Byte0-Byte3-Byte2, is received from the slave (sensor), the master must change the byte order to Byte0-Byte1-Byte2-Byte3 for the correct display of the value.

8.2 Modbus Holding Register Table

Modbus Register address	Data type	Data Length	Channel description	Unit	Res.*	R/W
0	FLOAT	4-Byte	Temperature	(°C,°F)	1	R
2	FLOAT	4-Byte	Relative humidity	(%)	3	R
6	FLOAT	4 Byte	Pressure dew point	(°Ctd or °Ftd)	1	R
8	FLOAT	4 Byte	Atmosphere dew point	(°Ctd atm,°Ftd atm)	1	R
10	FLOAT	4 Byte	Mixing ratio	(g/kg)	3	R
12	FLOAT	4 Byte	Absolute humidity	(g/m3, or mg/m3)	3 / 1	R
16	FLOAT	4 Byte	Volume ration	(ppm)	1	R
49	INT32U	4 Byte	Serial number	NA	1	R
55	INT32U	4 Byte	System status	NA	1	R
200	FLOAT	4 Byte	Temperature	NA	**	R
202	ASCII string (°C, or °F)	4 Byte	Unit of temperature	NA	1	R
204	INT16U	2-Byte	Resolution of temperature	NA	1	R
205	INT16U	2 Byte	Status temperature	NA	1	R
212	FLOAT	4 Byte	Humidity1	NA	**	R
214	ASCII string (% ,°Ctd,°Ftd , ,g/m3,mg/m3 ,g/kg, ppm, ,°Ctd	8-Byte	Unit of Humidity1	NA	1	R

Modbus Register address	Data type	Data Length	Channel description	Unit	Res.*	R/W
	atm, °Ftd atm)					
218	INT16U	2 Byte	Resolution of Humidity1	NA	1	R
219	INT16U	2 Byte	Status of Humidity1	NA	1	R
220	FLOAT	4 Byte	Humidity2	NA	**	R
222	ASCII string (% , °Ctd, °Ftd g/m3, mg/m3 , g/kg, ppm, °Ctd atm, °Ftd atm)	8 Byte	Unit of Humidity2	NA	1	R
226	INT16U	2 Byte	Resolution of Humidity2	NA	1	R
227	INT16U	2 Byte	Status of Humidity2	NA	1	R

* Res. denotes resolution.

** The resolution varies with units.

Remark: Units can be changed using the service software.

8.3 Interpretation of System Status

The device provides the device statuses via Modbus as well. The 32-bit data information is read as single bits. The meanings of these bits are described as follows.

Bit	Description
2	Dew point over range
3	Temperature over range
6	calibration over due
7	EEPROM broken
8	Dew point sensor broken

9 Installation

Before installing the transmitter, please make sure that all components listed below are included in your package.

Qty	Description	Item No.
1	S217 Dew Point Transmitter	Model specific (See section 9.4.)
1	2 m cable with M8 connector	No P/N
1	Instruction manual	No P/N
1	Calibration certificate	No P/N

9.1 Installation Requirements

- The flowing air or gas must pass the sensor tip for a proper measurement. This can be realized with a measurement chamber. For a installation without measuring chamber you need to concern the installation depth which is described in the section 9.2.3 Install without Measuring Chamber.
- Sensor orientation requirement is shown in the figure below.

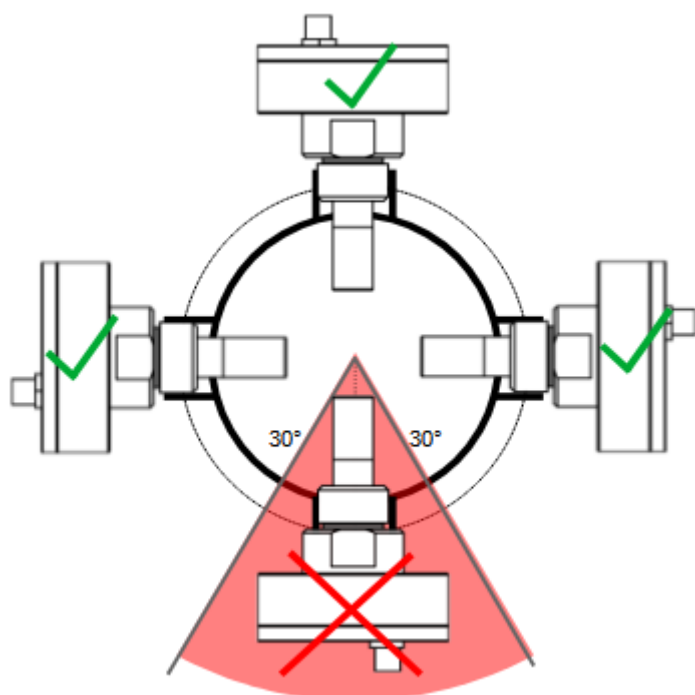

Install the device only in the recommended area, as shown in picture on the left.

The angle between the device and the centre vertical line of the tube must be greater than 30°.

An upside down installation is not permitted.

9.2 Installation Procedure

The following steps explain the procedure of an appropriate installation.

9.2.1 Install with Measuring Chamber A699 3491

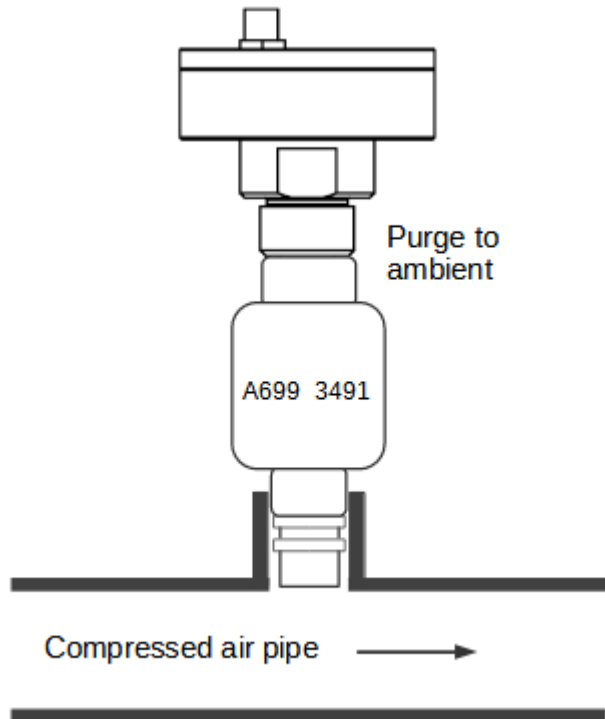

1. Mount the transmitter on the measuring chamber by using the G1/2" connection.
2. Make sure the transmitter is tightly sealed, therefore the sealing ring on the transmitter must be used.
3. Connect the measuring chamber to the compressed air system using a quick connector. Make sure the Dew Point Transmitter is screwed on the chamber before connecting. The measuring chamber will create a purge flow.

9.2.2 Install with By-pass Measuring Chamber A699 3493

For the model A699 3493, there are two installation methods:

Method 1: Full pass through by-pass installation

This method is to be used when the full air flow is passing through the measuring chamber.

1. Connect the inlet of the chamber using a 6 mm teflon hose to your system.

Note: The full flow must pass the measuring chamber. Ensure a certain flow rate to get fast response time.

2. Connect the outlet of the chamber to your system using the 6 mm hose quick connector.

See figure below for details.

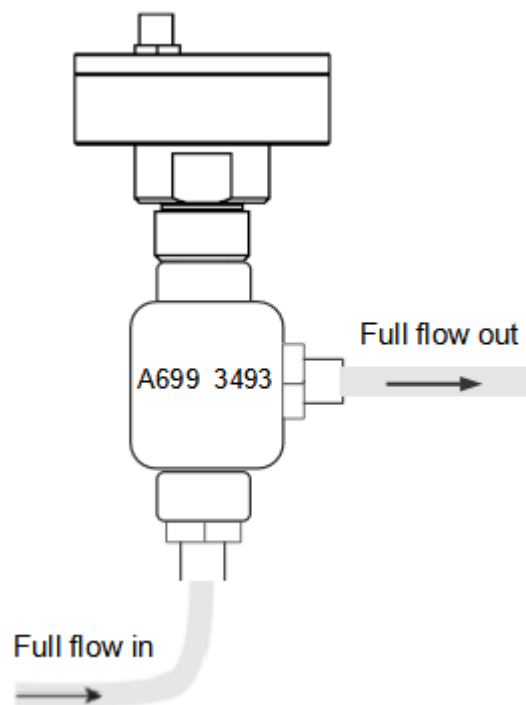

Method 2: By-pass installation

Note: In order to use the measurement chamber in a by-pass you must ensure a pressure difference between P1 and P2 as indicated in the picture below.

1. Connect the inlet of the chamber to your pipe system.
2. Connect the outlet of the chamber to your pipe system where the pressure is known to be lower than the inlet pressure.

Note: The pressure difference $P1 > P2$ is needed to create a by-pass flow through the chamber. If there is no pressure difference between P1 and P2, there will be no flow through the chamber and therefore the response time will be very slow or the device will not even respond at all to the dew point changes.

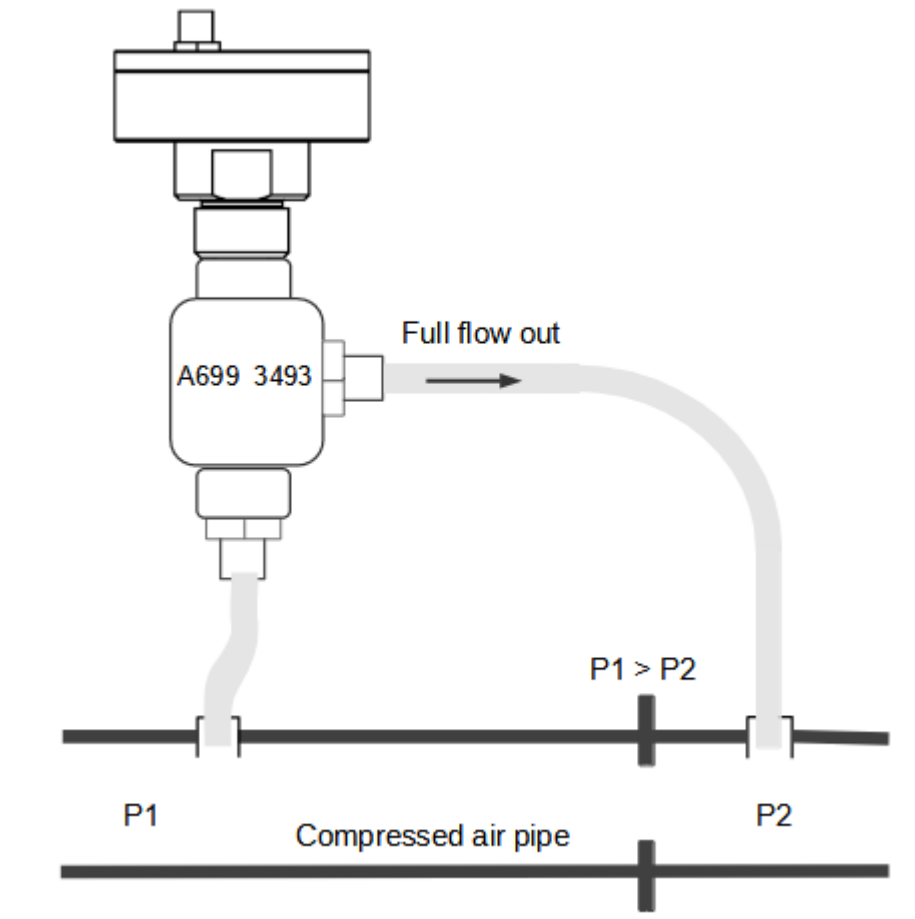

9.2.3 Install without Measuring Chamber

This is the full flow installation. The sensor is in the pipe.

Method 1: Install through a nozzle

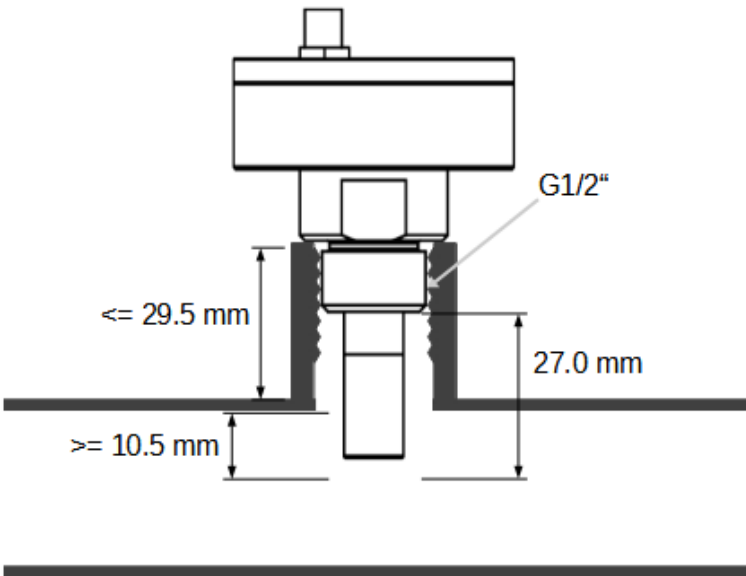

- Install the device only if the system is pressure-less.
- Check the size of the nozzle and make sure that no less than 1/3 of the sensor tip is inside of the pipe.
- The inner thread of the nozzle must be G 1/2".

Method 2: Install with NPT thread adapter

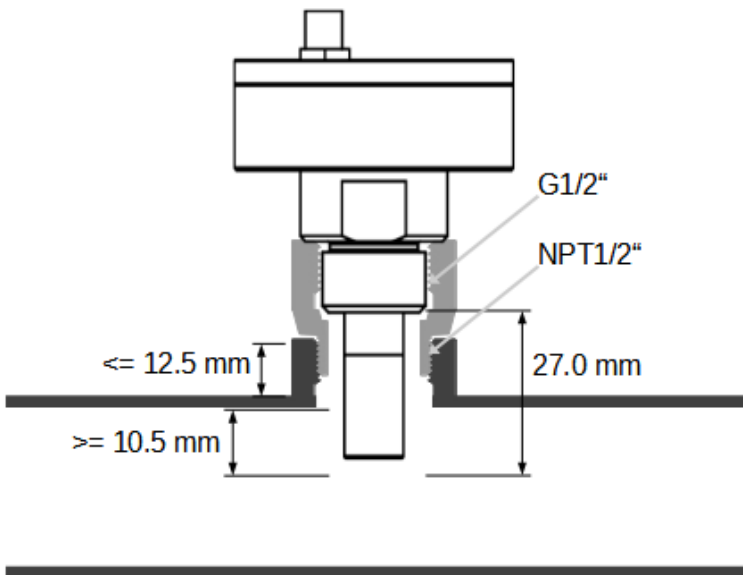

- Install the device only if the system is pressure-less.
- Please check the size of the nozzle and make sure not less than 1/3 of the sensor tip is inside of the pipe.
- The thread adapter (C190 0534) is used to adapt from G 1/2" sensor side to NPT 1/2" process connection.

9.3 Remove the Dew Point Transmitter

To remove the transmitter unscrew the transmitter from the measurement chamber or from the nozzle. Please observe that the system is pressureless when the transmitter is removed.

9.4 Order Information

Order no.	Description
S699 2170	S217-0, Dew Point Transmitter, 4 ... 20 mA (2-wire), -50 ... +20°C Td, G 1/2" thread, 50 bar, M8
S699 2173	S217-3, Dew Point Transmitter, 4 ... 20 mA (2-wire), -20 ... +50°C Td, G 1/2" thread, 50 bar, M8
S699 2174	S217-4, Dew Point Transmitter, 4 ... 20 mA (3-wire), -20 ... +50°C Td, G 1/2" thread, 50 bar, M8
S699 2175	S217-5, Dew Point Transmitter, 4 ... 20 mA (3-wire), -50 ... +20°C Td, G 1/2" thread, 50 bar, M8
S699 2176	S217-6, Dew Point Transmitter, 4 ... 20 mA (2-wire), -60 ... +20°C Td, G 1/2" thread, 50 bar, M8
S699 2177	S217-7, Dew Point Transmitter, 4 ... 20 mA (3-wire), -60 ... +20°C Td, G 1/2" thread, 50 bar, M8
S699 2178	S217-8, Dew Point Transmitter, Modbus/RTU, -60 ... +20°C Td, G1/2" thread, 5.0 MPa, M8
S699 2179	S217-9, Dew Point Transmitter, Modbus/RTU, -20 ... +50°C Td, G1/2" thread, 5.0 MPa, M8
A1390	S217, customized measuring range
A1391	S217, high pressure option 35 MPa (350 bar)
A554 2005	Service kit for sensor configuration including software
A699 3491	Measuring chamber for easy installation in compressed air system up to 15 bar
A699 3493	Measuring chamber bypass type (in and out 6 mm hose connection)
C198 0002	Sinter cap, stainless steel

10 Calibration

The transmitter is calibrated ex work. The exact calibration date is printed on the certificate which is supplied together with the transmitter. The accuracy of the transmitter is regulated by the on site conditions, parameters like oil, high humidity or other impurities can affect the calibration and furthermore the accuracy. However we recommend to calibrate the instrument at least once per year. The calibration is excluded from the instruments warranty. For this please contact the manufacturer.

11 Maintenance

Please observe from time to time the sinter cap. If it appears to be dirty, it is recommended to replace it for this please contact the manufacturer.



ATTENTION!

Contaminated filters can lead to longer response time and to wrong measurements.

12 Disposal or Waste



Electronic devices are recyclable material and do not belong in the household waste.

The transmitter, the accessories and its packings must be disposed according to your local statutory requirements. The dispose can also be carried by the manufacturer of the product, for this please contact the manufacturer.

SUTO iTEC GmbH

Grißheimer Weg 21
D-79423 Heitersheim
Germany

Tel: +49 (0) 7634 50488 00
Email: sales@suto-itec.com
Website: www.suto-itec.com

SUTO iTEC (ASIA) Co., Ltd.

Room 10, 6/F, Block B, Cambridge Plaza
188 San Wan Road, Sheung Shui, N.T.
Hong Kong

Tel: +852 2328 9782
Email: sales.asia@suto-itec.com
Website: www.suto-itec.com

SUTO iTEC Inc.

5460 33rd St SE
Grand Rapids, MI 49512
USA

Tel: +1 (616) 800-7886
Email: sales.us@suto-itec.com
Website: www.suto-itec.com

All rights reserved ©

Modifications and errors reserved

S217_im_en_2023-1
